

# Enabling the Real-Time Enterprise

[www.sensinode.com](http://www.sensinode.com)



*SENSINODE*

Zach Shelby, CTO

EWSN 2008



SENSINODE

Enabling the

Real-time Enterprise

I have a dream

The *Internet*

+

The *physical* world

=

The Internet of things

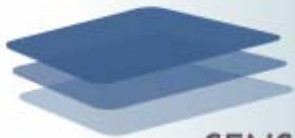

SENSINODE

Enabling the

Real-time Enterprise

# How we get to the Internet of Things

Arpanet,  
Usenet,  
BBSs

**Internet**

Web 2.0

**Web Services**

**Sensor Networks**

Ubicomm

**802.15.4 + 6LoWPAN + Web Services**

Ethernet

Proprietary  
ISM Radios



Modems  
Leased Lines  
RS232



**IEEE  
802.15.4**

**6LoWPAN**

**ULP BT**



**ISA100**

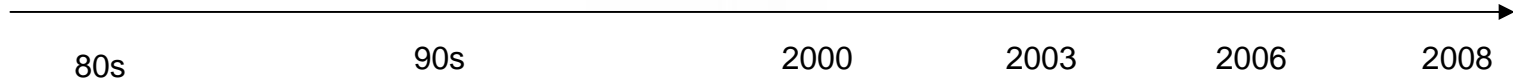

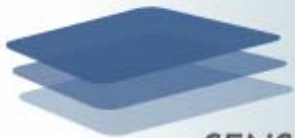

# Benefits of IP-based Sensor Networks

- IEEE 802.15.4
  - 802.15.4 standard
  - The new every wi

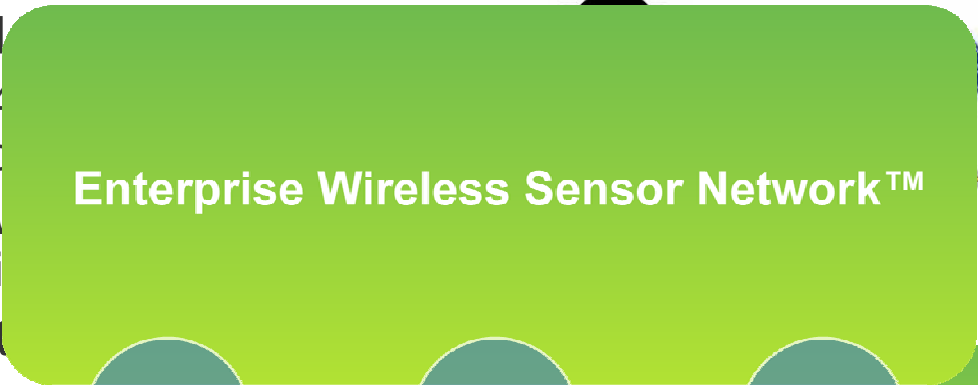

- The benefits
  - Open, long-l
  - Easy learnin
  - Transp
  - Netwo
  - Prover
  - “You nev

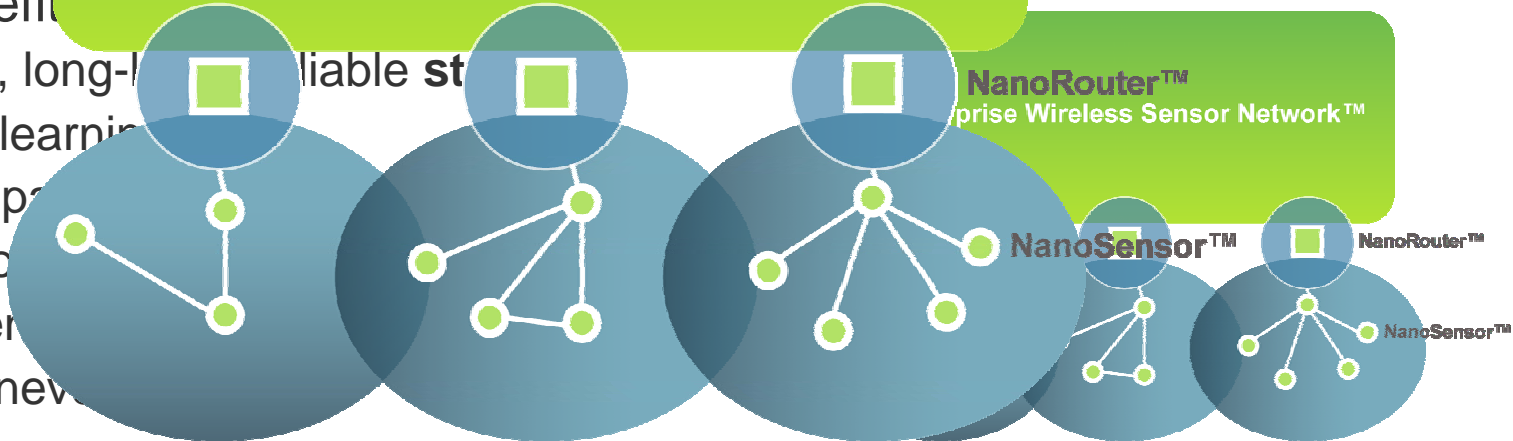

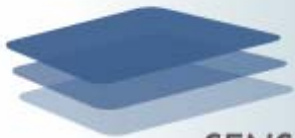

# Applications for IP-based WSNs

There are commercial, industrial, health and consumer markets for IP-based WSNs

1. **Logistics**, manufacturing and automation
2. **Smart buildings, environments and security**
3. **Healthcare** and well-being
4. Consumer applications e.g. **home automation** and health



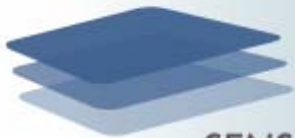

## IEEE 802.15.4 - The global standard

- Important standard for home networking, industrial control and building automation
- 802.15.4 Original
  - 250 kbps at 2.4 GHz (DSSS)
- 802.15.4a CSS and UWB
  - Up to 2 Mbps typical, accurate positioning
- Robust radio with flexible topology
  - Slotted CSMA algorithm
  - Beacon and beaconless modes
  - Reduced and full function nodes
- The next WiFi

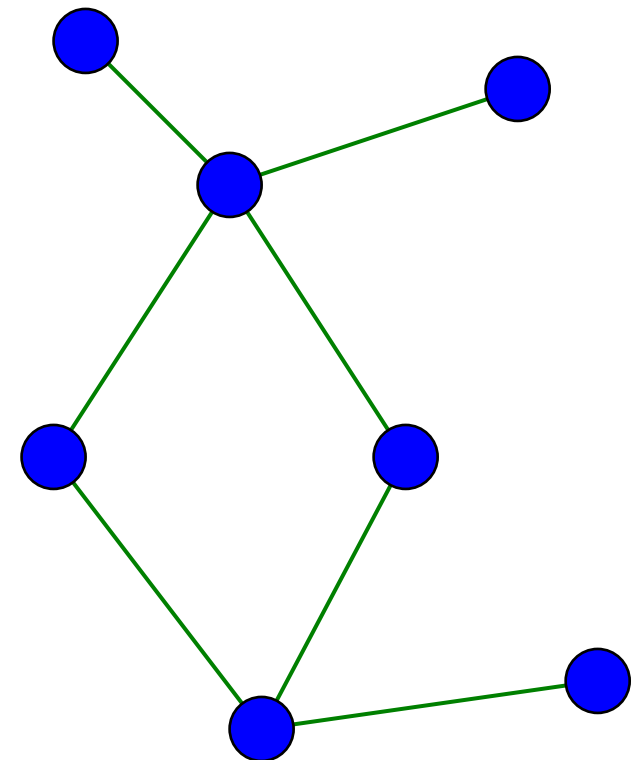

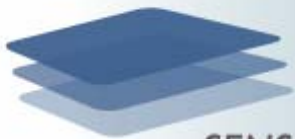

SENSINODE

Enabling the  
Real-time Enterprise

# Technology Comparison

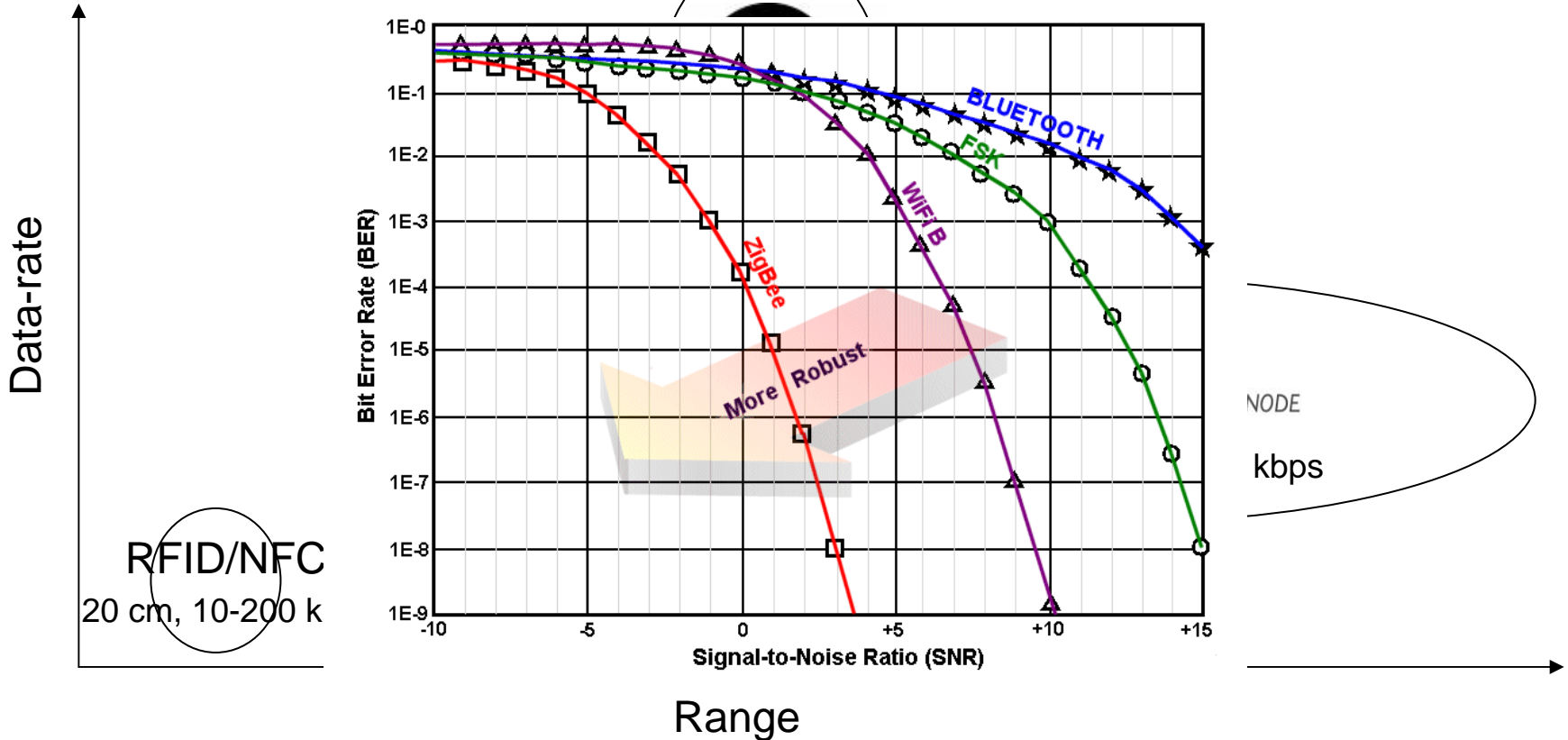

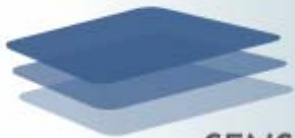

## The 802.15.4 Market

- 802.15.4 chip shipments are growing fast:
  - Up to 10 million units in 2006
  - Over 100 million units estimated for 2009
  - 200% growth per year
- OnWorld's industry expert survey showed that by 2009
  - 55% will support ISA100 (based on 6LoWPAN)
  - 40% will support WirelessHART
  - ZigBee will hold onto about 30%
  - Although not noted, most proprietary applications move to 6lowpan

Source: OnWorld

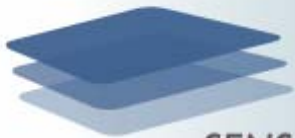

## Growth for Industrial WSN Applications

- **Asset monitoring 300%**
- **Machine health 122%**
- **Safety & security 86%**
- Tank level monitoring 75%
- Process monitoring 32%
- Facility environmental 14%
- Relief valves/steam traps 14%



Source: OnWorld

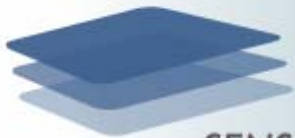

# 6LoWPAN - IP for Low-power Devices

- IETF Standard for IPv6 over IEEE 802.15.4
- 80% compression of headers
- Rich and flexible features
  - Auto-configuration
  - IPv6 fragmentation
  - UDP + ICMP
  - Mesh forwarding
- Common Socket API
- Super compact implementation
- Direct end-to-end Internet integration
- Extremely scalable

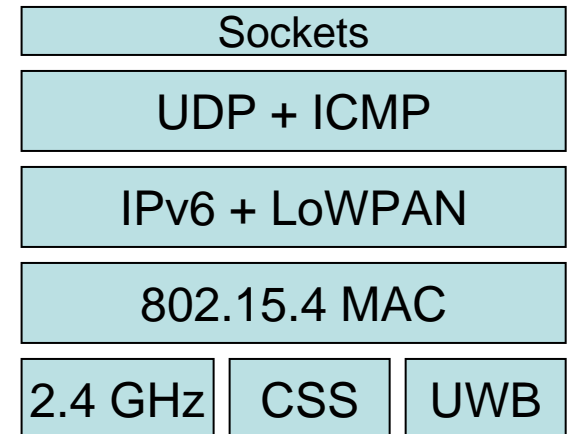
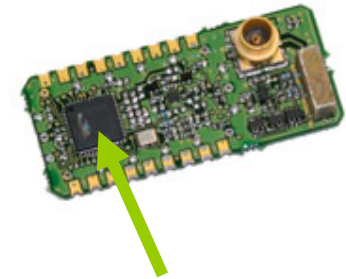



# 6LoWPAN Headers

- Orthogonal header format for efficiency
- Stateless header compression

Impossible case: Full TCP/IPv6

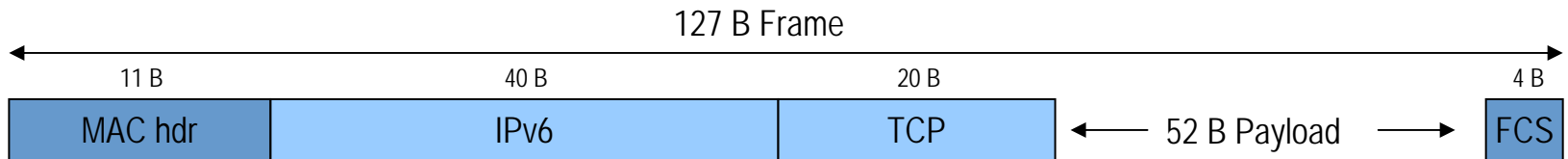

Best case: 6LoWPAN UDP/IPv6

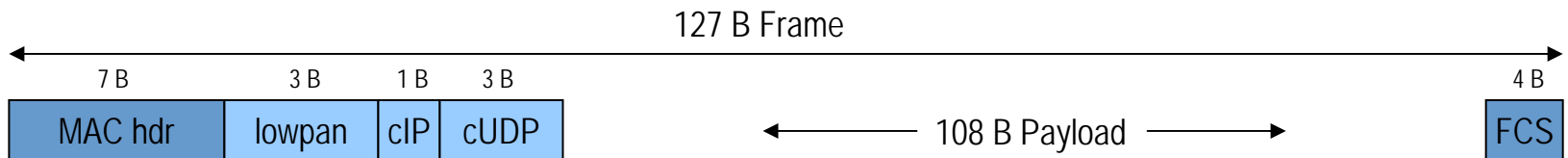

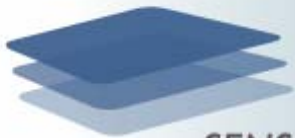

## ISA SP100



- The Instrumentation, Systems, and Automation Society (ISA)
- Society for promoting and standardizing automation
- Standardization activities accredited by ANSI
  
- ISA100 group standardizes wireless systems for automation
- ISA100.11a standardization is in progress
  - IEEE 802.15.4 2006 Radio Standard
  - 6LoWPAN Networking (6lowpan, IPv6, UDP)
  - Network gateways, monitoring, deployment, interoperability
  - Defining reliability classes 0 to 5
  - Draft available 4Q-2007, finished end of 1Q-2008

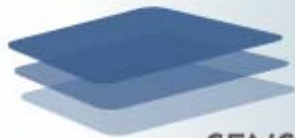

SENSINODE

# Enabling the Real-time Enterprise



- Z
- C
- P
- -
- Z
- -
- T
- Z
- C
- ju

- IEEE 802.15.4 defined
- ZigBee™ Alliance defined
- End manufacturer defined
- Layer function
- Layer interface

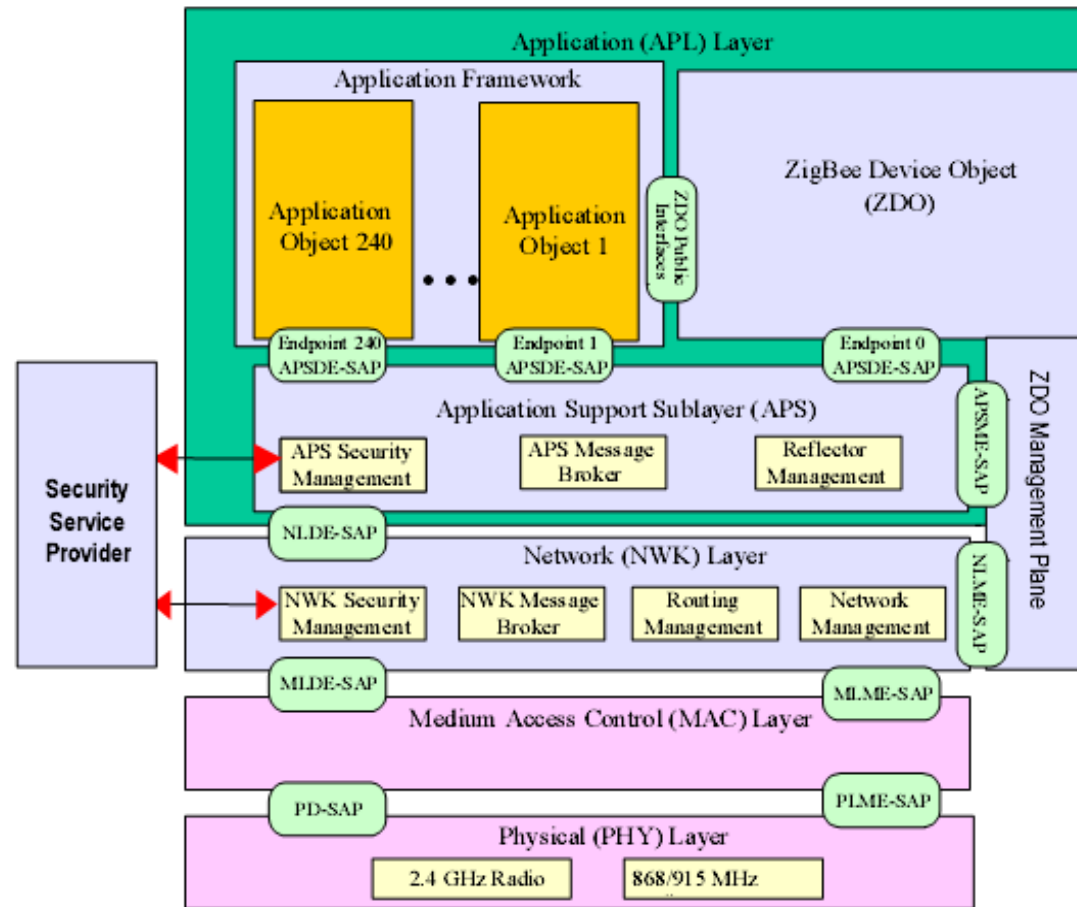

less

! or

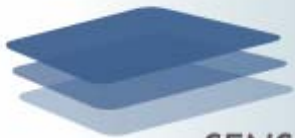

SENSINODE

Enabling the

Real-time Enterprise

## NanoStack™

- Sensinode's 6LoWPAN implementation
  - IEEE 802.15.4, IPv6, UDP, ICMP
- Simple, modular stack with a Socket API
- NanoMesh™ multihop forwarding
- Portable C implementation
- MSP430, AVR, CC2420, CC2430 support
- Support for the FreeRTOS microkernel
- PC tools included
- Dual-license open-source
- Sourceforge open-source project
- Download at [www.sensinode.com](http://www.sensinode.com)

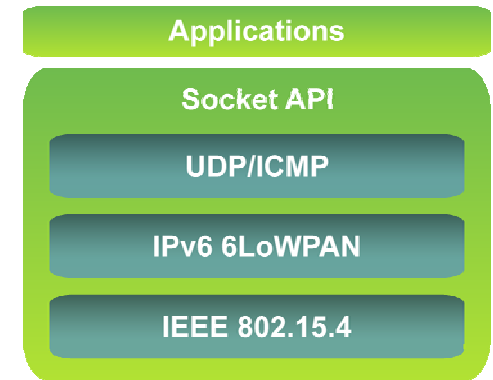

NanoStack™

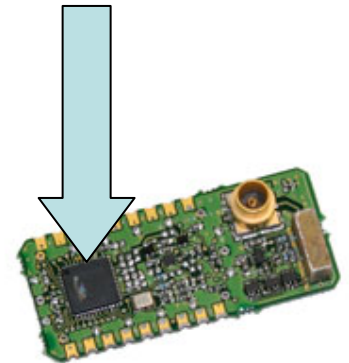

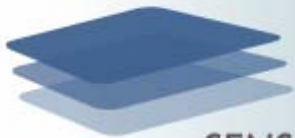

SENSINODE

Enabling the

Real-time Enterprise

# Thank You!

Zach Shelby, CTO  
zach@sensinode.com

Sensinode Ltd.  
Teknologiantie 6  
FIN-90570 Oulu  
+358(0)44-500-6778  
www.sensinode.com

